

MCAE-MHAE 115÷127



Microsystem
14,7÷26,3 kW



Condensing units and reversible condensing units, air cooled with axial fans.
Range equipped with hermetic scroll compressors.



main features

INDEX

Main features	page	2
Technical features	page	4
Electronic control	page	5
Performance	page	6
Dimensional and installation characteristics	page	8
Hydraulic connection	page	9
Electrical connection	page	11

Standard use conditions

MCAE are condensing units air cooled with axial fans.

MHAE are reversible condensing units air cooled with axial fans.

They are suitable in air conditioning installations connected with remote evaporators.

The machine is designed for outdoor installation.

The units comply with the following Directives:

- Machine Directive 89/392/CEE (MD);
- Low Voltage Directive 73/23/CEE (LVD);
- Electromagnetic Compatibility Directive 89/336/CEE (EMC);
- Pressurised Equipment Directive 97/23/CEE (PED).

Code guide

“RANGE” code

M Condensing unit	C Cooling only	A Air cooled	E Hermetic compressors
	H Heat pump		

“MODEL” code

115 - 127 Approximate cooling capacity (in kW)
--

Example: MCAE 122

- Air cooled condensing unit.
- Nominal cooling capacity: about 22 kW.



main features

Features

- Chassis made of Peraluman panels; base in galvanised sheet steel; sound proofed compressor chamber.
- Hermetic Scroll rotary compressor complete with internal overload protection.
- Air side exchanger composed of coil with copper pipes and aluminium fins, complete with protection grille.
- Axial fan featuring external rotor, internal overload cut-out, complete with protective grille.
- Flare refrigerant couplings with valve.
- Refrigerant circuit with mild copper tubes and silver alloy welding. Complete with filter drier, charge connections, safety high pressure switch with manual reset (in compliance with Directive 97/23/CEE (PED), safety low pressure switch with automatic reset, control pressure switch for winter operation (for MHAЕ 115), crankcase heater, liquid-humidity indicator, settable safety valves, thermostatic expansion valve (for MHAЕ), cycle inversion valve (for MHAЕ), non-return valve (for MHAЕ), liquid receiver and gas separator with safety valve (for MHAЕ).
- Unit with IP24 protection grade.
- Unit complete with:
 - ductable condensate discharge (for MHAЕ);
 - R 407C refrigerant charge foreseen for length of gas and liquid lines each of 7 m.

Electrical board

- Electrical board can be accessed from front panel compliant with IEC standards, complete with:
 - main power supply switch with interlocking safety door isolator;
 - electrical wiring arranged for power supply 400V-3ph-50Hz+N;
 - auxiliary circuit power supply 230V-1ph-50Hz derived from main power supply;
 - phase sequence controller;
 - automatic switches for protection of compressor and auxiliary circuit;
 - power contactor for compressor;
 - user interface terminal board ;
 - removable machine controls.
- Programmable microprocessor electronic board handled by the keyboard inserted in the machine. .
The board performs the following functions:
 - adjustment and control of cycle inversion (for MHAЕ); of the safety delays; of the compressor hour-run-meter; of the defrost cycles (for MHAЕ); of all the functions that control the working interventions of the unit devices;
 - complete protection of the unit, possible cut off of the machine and display of the active alerts;
 - display of operating devices by LED; of the heat pump or chiller operation by LED, (for MHAЕ); of defrosting in progress by LED (for MHAЕ);
 - self-diagnosis with continual checking of the machine operational status.
- Advanced functions:
 - arranged for serial connection, with RS485 outlet for logical dialogue with building automation, centralized systems and supervision networks.
 - computer assisted unit testing.

Accessories supplied loose

- **KSA** - Rubber antivibration mountings.
- **KFI** - Low ambient control for continuous control of the fan rotation speed down to outdoor air temperatures of -10°C during chiller operation, for ambient air temperatures up to 30°C during heat pump.
- **KIS** - RS 485 serial interface for interconnection with distributed intelligent systems for integrated building automation.
- **KCH** - RS232 hardware key to be connected to supervision systems, to combine with one or more KIS serial interface modules in centralized unit management system.

MODEL MCAE		115	118	122	127
Technical data					
Nominal cooling capacity (*)	kW	14,7	17,6	21,8	26,3
Sound pressure (***)	dB(A)	49	50	51	52
Hermetic Scroll compressor	n.	1	1	1	1
Fan	n.	1 x 0,38	1 x 0,38	1 x 0,38	1 x 0,38
Fan nominal air flow	L/h	5.900	5.500	6.300	6.000
R 407C refrigerant charge	kg	4,25	5,95	6,40	8,55
Polyester oil charge	L	1,90	1,60	3,15	3,15
Electrical data					
Total absorbed power (*)	kW	4,91	5,65	7,41	8,92
Power supply	V-ph-Hz	400-3-50	400-3-50	400-3-50	400-3-50
Auxiliary power supply	V-ph-Hz	230-1-50	230-1-50	230-1-50	230-1-50
Nominal current	A	8,7	10,4	13,2	17,2
Max. current	A	11,4	13,0	15,7	19,3
Starting current	A	66	74	98	130
Dimensions					
Length	L mm	1.326	1.326	1.716	1.716
Height	H mm	1.230	1.230	1.230	1.230
Depth	P mm	527	527	615	615

MODEL MHAЕ		115	118	122	127
Technical data					
Nominal heating capacity (**)	kW	15,8	19,9	24,5	29,9
Nominal cooling capacity (*)	kW	14,7	17,6	21,8	26,3
Sound pressure (***)	dB(A)	49	50	51	52
Hermetic Scroll compressor	n.	1	1	1	1
Fan	n.	1 x 0,38	1 x 0,38	1 x 0,38	1 x 0,38
Fan nominal air flow	L/h	5.900	5.500	6.300	6.000
R 407C refrigerant charge	kg	6,15	7,55	8,45	10,45
Polyester oil charge	L	1,90	1,60	3,15	3,15
Electrical data					
Total absorbed power (**)	kW	5,12	5,53	7,23	8,40
Power supply	V-ph-Hz	400-3-50	400-3-50	400-3-50	400-3-50
Auxiliary supply	V-ph-Hz	230-1-50	230-1-50	230-1-50	230-1-50
Nominal current	A	9,2	10,1	12,4	16,2
Max. current	A	11,4	13,0	15,7	19,3
Starting current	A	66	74	98	130
Dimensions					
Length	L mm	1.326	1.326	1.716	1.716
Height	H mm	1.230	1.230	1.230	1.230
Depth	P mm	527	527	615	615

(*) At the following conditions: condenser inlet air temperature 35°C; suction saturated gas temperature 7°C.

(**) At the following conditions: evaporator inlet air temperature 6°C W.B.; dew point 50°C.

(***) The sound pressure level in dB(A) refers to readings taken 5 m from the unit with a directionality factor equal to 2 (reduce this value by 3 dB(A) to obtain the open field value).

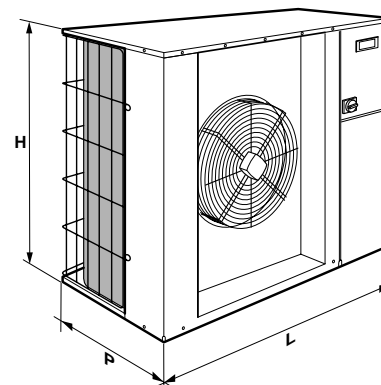

operation limits

Cooling cycle:

- Condenser inlet air temperature:
- version MCAE - MHAЕ 20°C - 43°C D.B.

Heating cycle:

- Evaporator inlet air temperature:
- version MHAЕ -5°C - 20°C D.B.

Keyboard and display description

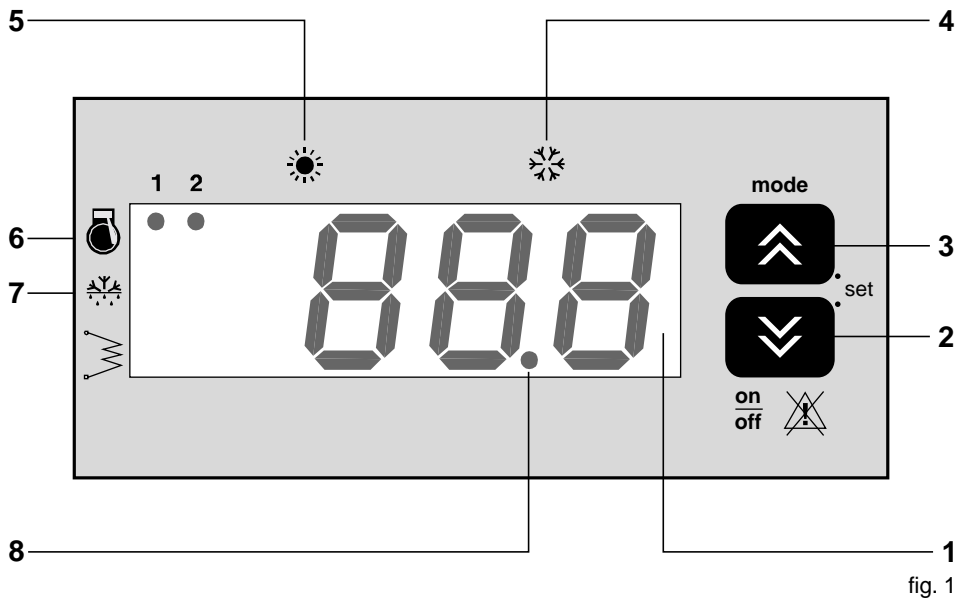

- 1 = DISPLAY:**
it displays the value of all the parameters, the codes of the possible alarms and the status of all the resources.
- 2 = ON/OFF, RESET - DOWN key:**
it allows to switch ON, OFF and the reset of possible alarms of the unit. Furthermore allows to scroll down the value of the parameters.
- 3 = MODE - UP key:**
it allows to scroll up the value of the parameters.
- 4 = Summer LED:**
it indicates that the unit is working in cooling cycle.
- 5 = Winter LED:**
it indicates that the unit is working in heating cycle.
- 6 = Compressor LED:**
it indicates that the compressor are ON or that a delay is in progress.
- 7 = Defrosting LED (only active on MHAE):**
it indicates that the unit is in the defrosting mode.
- 8 = Power supply LED:**
it indicates the presence of power supply in the unit.

N.B.

The keyboard with display makes it possible to view all process variables of the unit. For technical service, it makes it possible, with a password, to access the unit management parameters (access allowed only for authorized personnel).

KIS serial interface RS 485 (accessory)

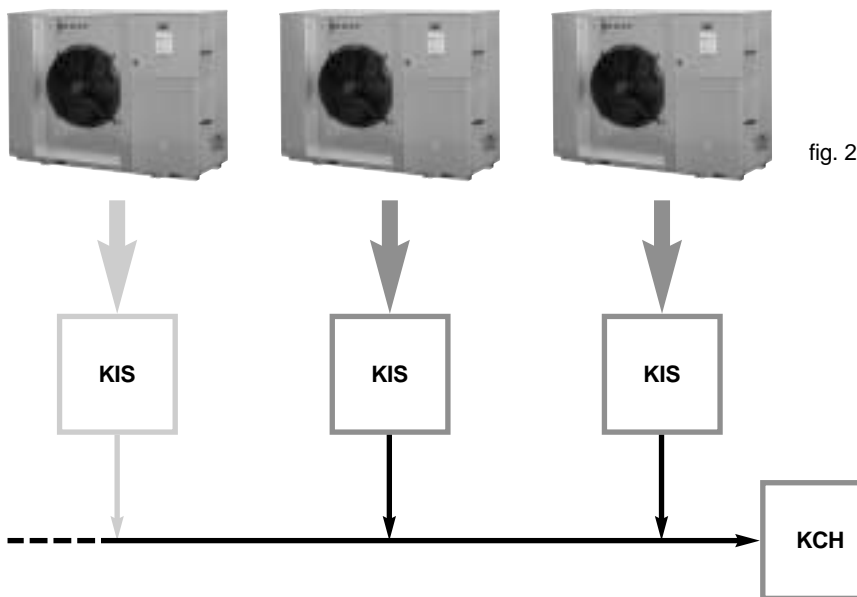

Serial connection

The units are equipped with an electronic controller, that is compatible with an external system through a serial communication line. The communication protocol allows the access to all the functions of the unit, such as:

- setting all the values accessible by the keyboard;
- reading all the process variables of the digital as well as analogue inputs and outputs;
- reading the various alarm codes and if necessary resetting them;
- reading all programming parameters or changing some of them.

Cooling capacity MCAE-MHAE 115

Ts (°C)	Ta/B.S.(°C)											
	20		25		30		35		40		43	
	QF	P	QF	P	QF	P	QF	P	QF	P	QF	P
	kW	kW	kW	kW	kW	kW	kW	kW	kW	kW	kW	kW
5	17,38	3,48	16,29	3,90	15,18	4,38	14,04	4,90	12,87	5,48	12,16	5,83
7	18,09	3,49	17,00	3,90	15,91	4,38	14,70	4,91	13,55	5,49	12,85	5,83
10	20,09	3,52	19,01	3,93	17,89	4,40	16,75	4,92	15,59	5,50	14,87	5,89

Heating capacity MHAE 115

Ta/B.S. (°C)	UR (%)	Tc (°C)									
		40		45		50		55		60	
		QT	P	QT	P	QT	P	QT	P	QT	P
		kW	kW	kW	kW	kW	kW	kW	kW	kW	kW
-5	90	10,63	3,78	10,17	4,21	9,74	5,02	–	–	–	–
0	90	13,20	3,81	12,74	4,27	12,32	5,04	11,89	5,59	–	–
5	85	15,67	3,85	15,21	4,31	14,78	5,10	14,35	5,68	14,06	5,93
7	85	17,59	3,86	17,14	4,33	15,80	5,12	15,38	5,71	15,09	5,96
10	80	18,25	3,87	17,79	4,35	17,36	5,13	16,93	5,74	16,64	5,99
15	80	20,71	3,91	20,25	4,36	19,82	5,17	19,39	5,77	19,11	6,03
20	80	23,29	3,93	22,83	4,38	22,40	5,20	21,97	5,81	21,68	6,05

Cooling capacity MCAE-MHAE 118

Ts (°C)	Ta/B.S.(°C)											
	20		25		30		35		40		43	
	QF	P	QF	P	QF	P	QF	P	QF	P	QF	P
	kW	kW	kW	kW	kW	kW	kW	kW	kW	kW	kW	kW
5	20,73	3,99	19,46	4,49	18,18	5,03	16,89	5,65	15,58	6,37	14,79	6,76
7	21,50	4,00	20,24	4,49	18,97	5,03	17,60	5,65	16,28	6,37	15,53	6,82
10	24,00	4,01	22,74	4,50	21,46	5,04	20,16	5,66	18,86	6,38	18,06	6,82

Heating capacity MHAE 118

Ta/B.S. (°C)	UR (%)	Tc (°C)									
		40		45		50		55		60	
		QT	P	QT	P	QT	P	QT	P	QT	P
		kW	kW	kW	kW	kW	kW	kW	kW	kW	kW
-5	90	14,05	4,54	13,50	4,66	12,91	5,51	–	–	–	–
0	90	16,95	4,58	16,40	4,71	15,81	5,51	15,39	6,05	–	–
5	85	19,82	4,60	19,27	4,80	18,68	5,52	18,25	6,06	17,67	6,88
7	85	20,80	4,60	22,07	4,81	19,90	5,53	19,51	6,06	20,77	6,94
10	80	23,00	4,61	22,46	4,81	21,87	5,54	21,44	6,07	20,86	6,95
15	80	26,16	4,62	25,61	4,82	25,02	5,54	24,59	6,07	24,01	6,97
20	80	29,31	4,62	28,76	4,84	28,17	5,55	27,74	6,08	27,16	6,98

P = Total absorbed electrical power
 QF = Cooling capacity
 QT = Heating capacity

Ta/B.S. = Dry bulb ambient temperature
 Tc = Dew point
 Ts = Suction saturated gas temperature
 UR = Relative humidity

Cooling capacity MCAE-MHAE 122

Ts (°C)	Ta/B.S.(°C)											
	20		25		30		35		40		43	
	QF	P	QF	P	QF	P	QF	P	QF	P	QF	P
	kW	kW	kW	kW	kW	kW	kW	kW	kW	kW	kW	kW
5	25,86	5,33	24,21	5,94	22,44	6,64	20,57	7,41	18,57	8,27	17,32	8,84
7	27,10	5,33	25,45	5,94	23,68	6,64	21,80	7,41	19,80	8,29	18,55	8,84
10	30,68	5,34	29,03	5,96	27,26	6,65	25,39	7,42	23,39	8,30	22,14	8,86

Heating capacity MHAE 122

Ta/B.S. (°C)	UR (%)	Tc (°C)									
		40		45		50		55		60	
		QT	P	QT	P	QT	P	QT	P	QT	P
		kW	kW	kW	kW	kW	kW	kW	kW	kW	kW
-5	90	17,10	5,95	16,51	6,64	15,88	7,17	–	–	–	–
0	90	20,45	6,00	19,86	6,69	19,23	7,17	18,77	7,83	–	–
5	85	24,17	6,04	23,58	6,74	22,95	7,22	22,49	7,88	21,87	8,49
7	85	25,43	6,05	26,67	6,75	24,50	7,23	24,04	7,89	25,28	8,51
10	80	28,39	6,05	27,80	6,76	27,17	7,24	26,71	7,92	26,08	8,53
15	80	33,47	6,05	32,89	6,76	32,25	7,25	31,79	7,93	31,17	8,54
20	80	39,18	6,04	38,59	6,74	37,96	7,24	37,50	7,92	36,88	8,53

Cooling capacity MCAE-MHAE 127

Ts (°C)	Ta/B.S.(°C)											
	20		25		30		35		40		43	
	QF	P	QF	P	QF	P	QF	P	QF	P	QF	P
	kW	kW	kW	kW	kW	kW	kW	kW	kW	kW	kW	kW
5	31,19	6,35	29,21	7,11	27,10	7,96	24,85	8,93	22,47	10,02	20,97	10,73
7	32,65	6,34	30,66	7,09	28,55	7,95	26,30	8,92	23,92	10,02	22,42	10,73
10	37,16	6,33	35,18	7,08	33,06	7,94	30,81	8,90	28,43	9,99	26,93	10,71

Heating capacity MHAE 127

Ta/B.S. (°C)	UR (%)	Tc (°C)									
		40		45		50		55		60	
		QT	P	QT	P	QT	P	QT	P	QT	P
		kW	kW	kW	kW	kW	kW	kW	kW	kW	kW
-5	90	20,26	6,60	19,67	7,45	19,12	8,34	–	–	–	–
0	90	24,28	6,65	23,69	7,45	23,13	8,35	22,61	9,41	–	–
5	85	28,96	6,68	28,37	7,48	27,81	8,39	27,29	9,42	26,80	9,85
7	85	31,04	6,70	30,46	7,49	29,90	8,40	31,03	9,42	32,37	9,86
10	80	34,45	6,70	33,86	7,49	33,30	8,40	32,78	9,44	32,29	9,86
15	80	40,74	6,68	40,15	7,48	39,59	8,39	39,07	9,44	38,58	9,85
20	80	47,97	6,65	47,38	7,45	46,82	8,34	46,30	9,42	45,80	9,85

P = Total absorbed electrical power
 QF = Cooling capacity
 QT = Heating capacity

Ta/B.S. = Dry bulb ambient temperature
 Tc = Dew point
 Ts = Suction saturated gas temperature
 UR = Relative humidity

dimensional and installation characteristics

MCAE - MAHE: 115-118-122-127

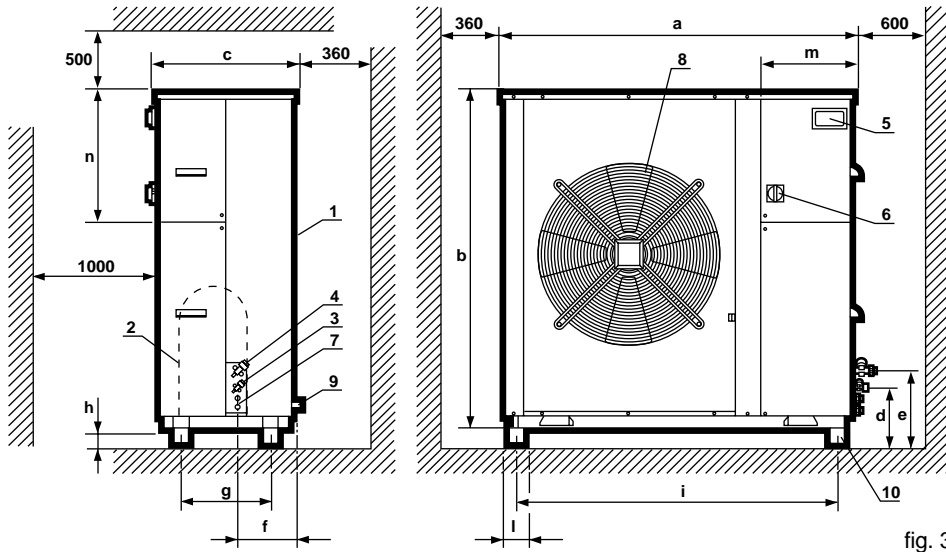

1. Condenser/evaporator
2. Compressor
3. Liquid line connection
4. Gas line connection
5. Control keyboard
6. Main switch
7. Power input
8. Fan
9. Condensate discharge
10. KSA - rubber anti-vibration mountings.

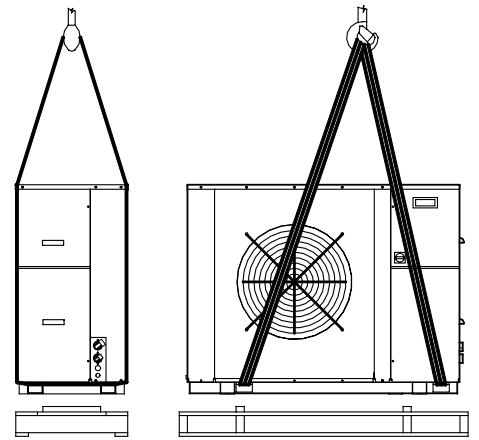

fig. 3

MODEL		115	118	122	127
Dimensions					
a	mm	1.326	1.326	1.716	1.716
b	mm	1.230	1.230	1.230	1.230
c	mm	527	527	615	615
d	mm	181	181	181	181
e	mm	256	256	256	256
f	mm	209	209	249	249
g	mm	338	338	512	512
h	mm	50	50	60	60
i	mm	1.265	1.265	1.010	1.010
l	mm	65	65	80	80
m	mm	352	352	545	545
n	mm	492	492	492	492
Liquid line coupling	mm	12,7-1/2"	15,9-5/8"	15,9-5/8"	15,9-5/8"
Gas line coupling	mm	19,1-3/4"	19,1-3/4"	22,2-7/8"	22,2-7/8"
Condensate discharge \varnothing	mm	30	30	30	30
Weight MCAE	kg	180	200	260	290
Weight MAHE	kg	200	210	280	300

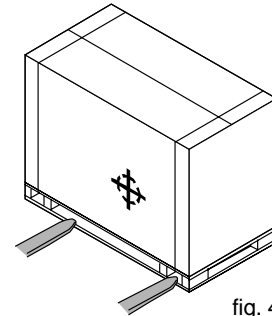

fig. 4

Installation

- The unit is fitted with a 3-way flare refrigerant connection with cock.
- The flare pipes are equipped standard with the machine so as to allow joining between the condenser flare connections with cocks and the system line. Connection is made through braze welding.
- The machine must be installed outdoors. Segregate the units if installed in areas accessible to persons under 14 years of age.
- The unit can be supplied on request with anti-vibration rubber supports (KSA).
- The unit should be placed in horizontal position, respecting the minimum technical service distances recommended in figure no. 5, keeping in mind accessibility to the refrigerant and electrical connections.
- The unit features a condensate drain pan (MAHE only).

N.B.:

- Special care should be taken when moving the unit in order to avoid damage to the external structure and to the internal mechanical and electrical components (figure 4).
- Storage temperature limits: $-9^{\circ}\text{C}/+45^{\circ}\text{C}$. Do not stack units.

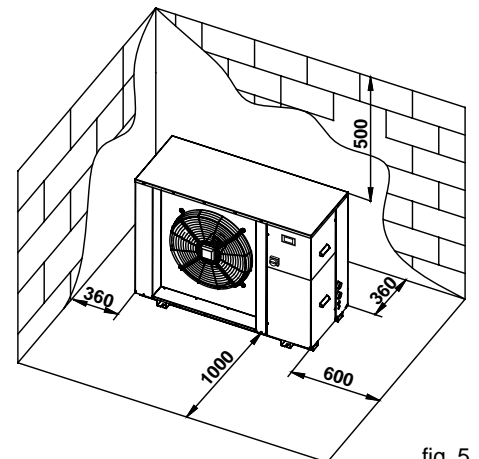

fig. 5

Suggested diameters

MODEL	Equivalent distance (*)	m	5	10	15	20	25
	Line						
115	Liquid o.Ø	mm	12,7-1/2"	12,7-1/2"	12,7-1/2"	12,7-1/2"	12,7-1/2"
	Gas o.Ø	mm	19,1-3/4"	19,1-3/4"	19,1-3/4"	22,2-7/8"	22,2-7/8"
118	Liquid o.Ø	mm	15,9-5/8"	15,9-5/8"	15,9-5/8"	15,9-5/8"	15,9-5/8"
	Gas o.Ø	mm	19,1-3/4"	19,1-3/4"	25,4-1"	25,4-1"	25,4-1"
122	Liquid o.Ø	mm	15,9-5/8"	15,9-5/8"	15,9-5/8"	15,9-5/8"	15,9-5/8"
	Gas o.Ø	mm	22,2-7/8"	22,2-7/8"	25,4-1"	25,4-1"	31,8-1 1/4"
127	Liquid o.Ø	mm	15,9-5/8"	15,9-5/8"	15,9-5/8"	15,9-5/8"	15,9-5/8"
	Gas o.Ø	mm	22,2-7/8"	22,2-7/8"	25,4-1"	25,4-1"	31,8-1 1/4"

(*) The equivalent length can be roughly obtained by adding 1.2 m for each bend and 1 m for each change of cross-section to the straight pipes

N.B.:
The refrigerant pipes connected to the terminal unit should be made in EN 12735 refrigerant systems copper.
For further details see the user's manual.

Connection diagram

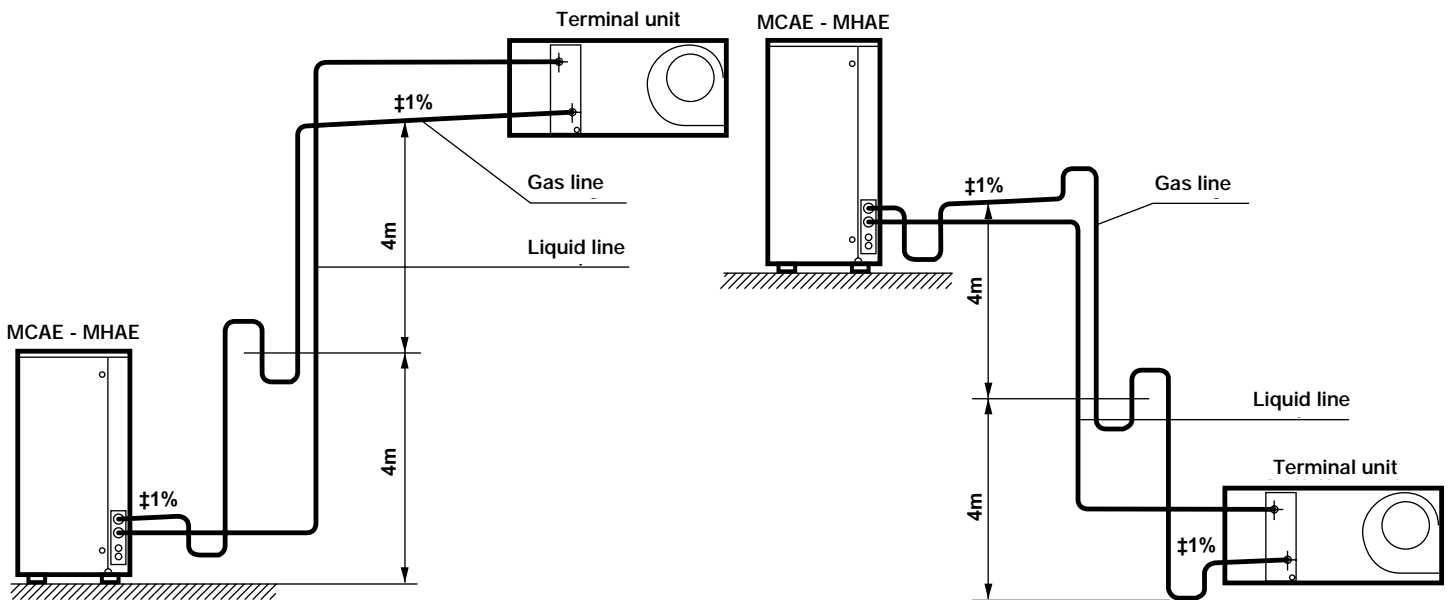

fig. 6

Height difference

The maximum admitted difference in height between the outdoor and the indoor unit is 8 m; greater height differences are possible provided traps are included every 6 m on the gas line.
The maximum equivalent distance of the connection line is 25 m.

refrigerant circuits diagrams

MCAE 115-118-122-127

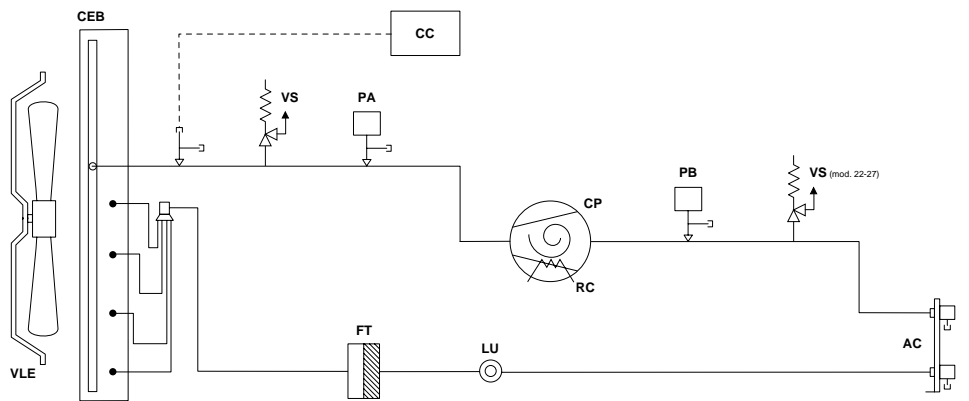

fig. 7

MHAE 115-118-122-127

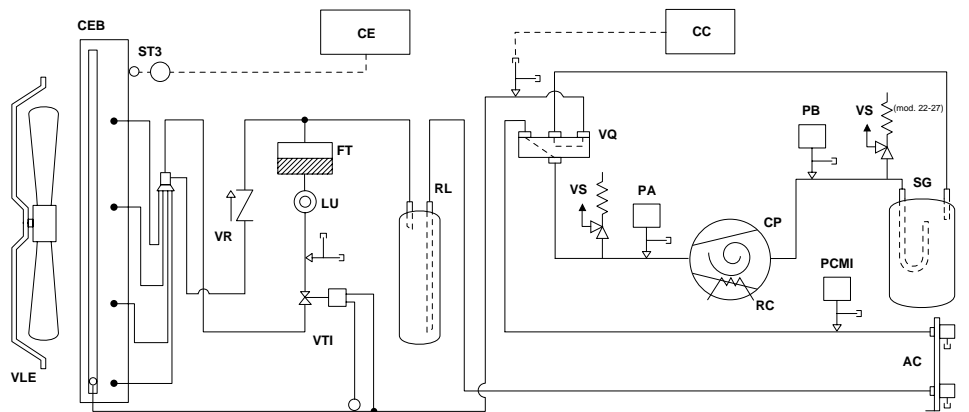
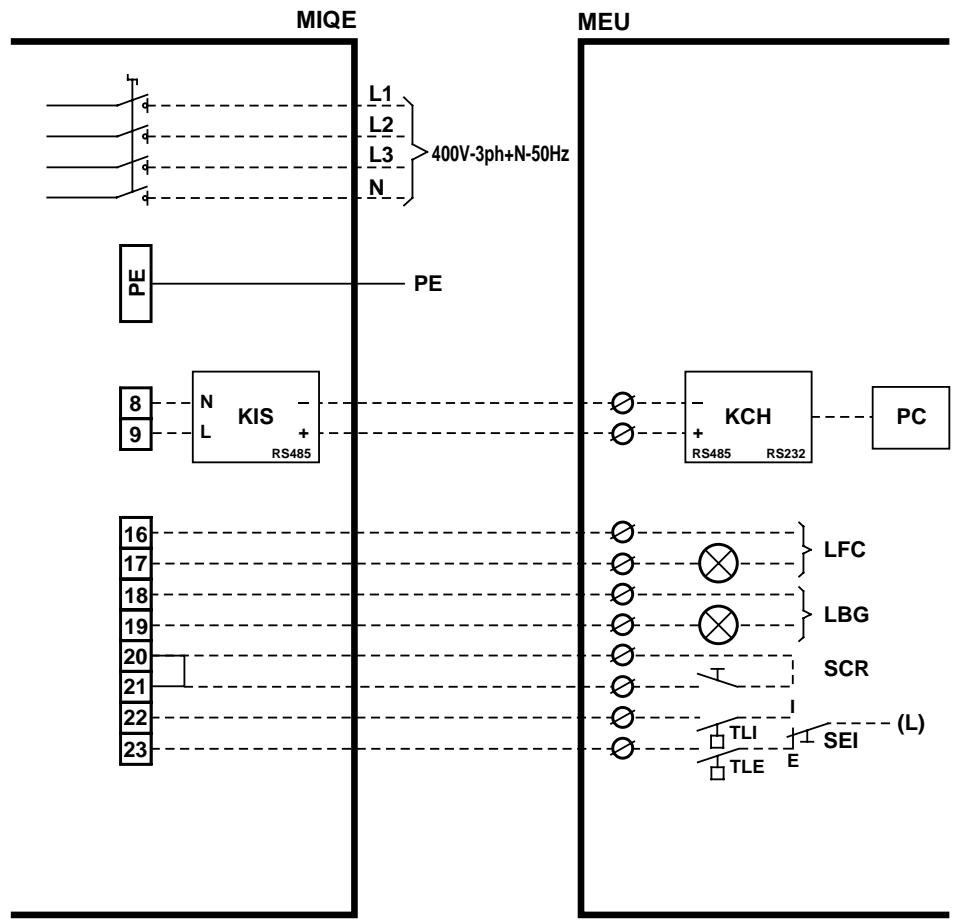

fig. 8

- | | |
|---|--|
| AC = Flare connections with 3-way valve | RC = Crankcase heater |
| CC = Condensation control (KFI accessory) | RL = Liquid receiver |
| CE = Microprocessor electronic controller | SG = Gas separator |
| CEB = Finned condenser/evaporator coil | ST3 = Defrost management temperature probe |
| CP = Compressor | VLE = Axial fan |
| FT = Filter drier | VQ = Cycle inversion valve |
| LU = Liquid humidity indicator | VR = Non-return valve |
| PA = Manual reset H.P. switch | VS = Safety valve |
| PB = Automatic reset L.P. switch | VTI = Winter thermostatic valve |
| PCMI = Winter maximum control pressure switch (only for MHAE 115) | |

MCAE-MHAE 115-118-122-127



Electrical connections

- The electrical board can be accessed from the front panel of the unit.
- Connections must be made by qualified personnel in compliance with current standards and with the diagrams supplied with the machine.
- Always install, near the machine in a protected area, an automatic main switch with a characteristic delay curve, of suitable capacity and interruption power, and with a minimum contact aperture of 3 mm.
- The earth connection of the unit is compulsory by law and protects the user's safety when the machine is operating.

fig. 9

- MIQE** = Terminal board inside the electric cabinet
- MEU** = User external terminal board
- LBG** = General main alarm lamp (24 Vac supply)
- LFC** = Compressor working lamp (24 Vac supply)
- KIS** = RS485 serial interface
- KCH** = RS232 hardware key
- L** = Lines
- N** = Neutral
- PE** = Earth clamp
- PC** = Personal computer
- SCR** = Remote control switch (dry contact control)
- SEI** = Summer/winter switch (to be connected to the line)
- TLE** = Summer working thermostat
- TLI** = Winter working thermostat
- = Connection by the installer

MCAE-MHAE 115÷127

RHOSS s.p.a.

Via Oltre Ferrovia, 32 - 33033 Codroipo (UD) - Italy
tel. +39 0432 911611 - fax +39 0432 911600
rhoss@rhoss.it - www.rhoss.it - www.rhoss.com

IRSAP-RHOSS Clima Integral S.L.

C/ Leonardo da Vinci, 4 - Pol. Ind. Camí Ral
08850 Gavà (Barcelona) - Spain
telf. +34 93 6334733 - fax +34 93 6334734
rhoss@irsap-rhoss.com - www.rhoss.es

Ir Group S.A.S.

7 rue du Pont à Lunettes - 69390 Vourles - France
tel. +33 (0)4 72318631 - fax +33 (0)4 72318632
irsaprhoss@irgroup.fr

RHOSS Deutschland GmbH

Hölzlestraße 23, D-72336 Balingen, OT Engstlatt - Germany
tel. +49 (0)7433 260270 - fax +49 (0)7433 2602720
info@rhoss.de - www.rhoss.de

Sedi commerciali Italia: / Italy branch offices:

Area Nord-Est: 33033 Codroipo (UD) - Via Oltre Ferrovia, 32
tel. +39 0432 911611 - fax +39 0432 911600

Area Nord-Ovest: 20041 Agrate Brianza (MI)
Centro Colleoni - Palazzo Taurus, 1
tel. +39 039 6898394 - fax +39 039 6898395

Area Nord-Ovest - Uffici di Firenze:
50127 Firenze - Via F. Baracca, 148/R
tel. +39 055 4360492 - fax +39 055 413035

Area Centro-Sud: 00199 Roma - Viale Somalia, 148
tel. +39 06 8600699-707 - fax +39 06 8600747

Area Sud - Filiale di Napoli:
80143 Napoli - Via G. Porzio - Centro Direzionale - Isola G8
tel. +39 081 7879121 - fax +39 081 7879135

Area Sud - Uffici di Bari:
70124 Bari - Via Lucarelli, 60/N
tel. +39 080 5013644 - fax +39 080 5021159



RHOSS S.P.A. declines all responsibilities for possible mistakes in the catalogue and reserves the right to alter the features of their products without notice in the interests of continuous improvement.